

See discussions, stats, and author profiles for this publication at: <https://www.researchgate.net/publication/301639998>

Hybrid filter for 12-pulse HVDC converters

Article in *Journal of Electrical Engineering* · April 2016

CITATIONS

2

READS

2,259

4 authors:



Ahmed Lamine Dourari

3 PUBLICATIONS 2 CITATIONS

[SEE PROFILE](#)



Mohammed-Karim Fellah

University of Sidi-Bel-Abbes

173 PUBLICATIONS 877 CITATIONS

[SEE PROFILE](#)



Mohamed Khafir

University of Sidi-Bel-Abbes

67 PUBLICATIONS 174 CITATIONS

[SEE PROFILE](#)



Chebabhi Ali

Université de M'sila

55 PUBLICATIONS 476 CITATIONS

[SEE PROFILE](#)

Some of the authors of this publication are also working on these related projects:



Grid Connected Photovoltaic Sytem [View project](#)



Electrical Power systems [View project](#)

Hybrid filter for 12-pulse HVDC converters

Ahmed Lamine DOURARI¹, Mohammed Karim FELLAH¹, Mohamed KHATIR¹, Ali CHEBABHI²

¹ICEPS Laboratory, Department of Electrical Engineering, Djillali Liabes University
Sidi Bel Abbas, Algeria, E-mails:lamine.dourari@gmail.com

²Faculty of Science and Technology, University of Bordj Bou Arreridj, Algeria.

Abstract: In HVDC (High Voltage Direct Current) systems the converters produce current harmonics that inject into the DC transmission lines and the AC grid. Passive filters and Active filter have been used to reduce the harmful effects of the harmonic currents. In this paper the current harmonics can be compensated by using the Hybrid Filter that consists of a shunt active power filter (SAPF) connected with passive filter. The control strategy adopted use synchronous reference frame (SRF) theory. The reference current can be calculated by dq transformation. An improved generalized integrator control was proposed to improve the performance of SAPF. These topologies are applied in 12-pulse HVDC Converter (345 kV) for reactive power compensation and harmonic currents suppression generated by nonlinear loads. The simulation model is developed and performed using MATLAB-Simulink and SimPowerSystem Toolbox.

Key words: HVDC, Total harmonic distortion, Shunt passive filter, Hybrid filter, SRF.

1. Introduction

A bipolar HVDC transmission system consists of two converter stations connected by a DC overhead line or cable. In HVDC system during the operation of converters (inverters or rectifiers), characteristic and non characteristic harmonics are generated [1]. With the increase of converter stations, it is possible that the effect of harmonics will be detrimental to grid reliability and increase energy loss. The conventional solution to reduce the harmonics can be accomplished by installing passive LC filters in HVDC system [2,3]. However, the main disadvantage of these filters is that they provide a fixed solution and do not allow fine tuning. Moreover, they suffer from congestion problems and aging [4,5].

The recent advances in power semiconductor devices have resulted in the development of Active Power Filters (APF) for harmonic suppression.

The APF may be part of several solutions in the HVDC scheme to improve reactive power exchange with the AC grid and to improve the dynamic stability [6].

The active power filters were studied for harmonics compensation in the industrial power network, since the principle of compensation were suggested by H. Sasaki and T. Machida in 1971 [7]. In these years, progress on the active filtering has been continued only at the theoretical stage in laboratory. The technology of the semiconductors

was not developed yet enough for the practical establishment of the principle of compensation. A few years later, the technology of power semiconductors reached remarkable blossoming. This phenomenon stimulated the interest in the research of active filtering for the harmonics compensation.

Hybrid Active Power Filter (HAPF) topologies have been developed to solve the problems of harmonic currents and reactive power effectively. Using low cost passive filters in the hybrid active filter, the power rating of active converter is reduced compared with that of pure active filters. The hybrid filters are cost effective and became more practical in industry applications [8-10].

The performance of SAPF depends on the strategy used to generate the reference harmonic currents. Several researchers described the effect of reference harmonic currents generation on the performance of SAPF, such as the Instantaneous Reactive Power theory (IRP) or the instantaneous active and reactive power (pq) [4,11] and Synchronous Reference Frame theory (SRF) [12,13]. In all of these works, has been confirmed that the SRF theory is most widely used, simple structure, easy to realize, and gives good performance than others theories.

Previously, researches have been conducted on harmonic reduction methods using active filters for HVDC networks were introduced in [14-16]:

In this paper, hybrid active filter consisting of shunt active filter (SAPF) with shunt connected passive filters for low order dominant harmonics are studied. For the reference harmonic currents generation of the SAPF, we used the synchronous reference frame theory (SRF), the PWM technique is employed to generate the inverter gating signals.

2. Synchronous Reference Frame Theory (SRF)

The control strategy used in this work, to compensate harmonic currents, is based on the synchronous reference frame theory (SRF). The principle of this technique is described in [13,17]. The three phase currents i_a , i_b and i_c are transformed from three phase (abc) reference frame to two phase's (α - β) stationary reference frame currents i_α and i_β using:

$$\begin{bmatrix} i_\alpha \\ i_\beta \end{bmatrix} = \sqrt{\frac{2}{3}} \begin{bmatrix} 1 & -\frac{1}{2} & \frac{1}{2} \\ 0 & \frac{\sqrt{3}}{2} & -\frac{\sqrt{3}}{2} \end{bmatrix} \begin{bmatrix} i_a \\ i_b \\ i_c \end{bmatrix} \quad (1)$$

Using a PLL (Phase Locked Loop), we can generate $\cos(\hat{\theta})$ and $\sin(\hat{\theta})$ from the phase voltage source V_a , V_b and V_c . The currents expression i_α and i_β in (d - q) reference frame are given by:

$$\begin{bmatrix} i_d \\ i_q \end{bmatrix} = \begin{bmatrix} \sin(\hat{\theta}) & -\cos(\hat{\theta}) \\ \cos(\hat{\theta}) & \sin(\hat{\theta}) \end{bmatrix} \begin{bmatrix} i_\alpha \\ i_\beta \end{bmatrix} \quad (2)$$

These components can then be expressed as the sum of a DC component and AC component.

$$\begin{bmatrix} i_d \\ i_q \end{bmatrix} = \begin{bmatrix} \bar{i}_d + \tilde{i}_d \\ \bar{i}_q + \tilde{i}_q \end{bmatrix} \quad (3)$$

With \bar{i}_d , \bar{i}_q are the continuous components of i_d and i_q , and \tilde{i}_d , \tilde{i}_q are the alternative components of i_d and i_q . From equation (2), we can express the current components along the axes ($\alpha\beta$) by:

$$\begin{bmatrix} i_\alpha \\ i_\beta \end{bmatrix} = \begin{bmatrix} \sin(\hat{\theta}) & -\cos(\hat{\theta}) \\ \cos(\hat{\theta}) & \sin(\hat{\theta}) \end{bmatrix}^{-1} \begin{bmatrix} i_d \\ i_q \end{bmatrix} \quad (4)$$

$$\begin{bmatrix} i_\alpha \\ i_\beta \end{bmatrix} = \begin{bmatrix} \sin(\hat{\theta}) & \cos(\hat{\theta}) \\ -\cos(\hat{\theta}) & \sin(\hat{\theta}) \end{bmatrix} \begin{bmatrix} \bar{i}_d \\ \bar{i}_q \end{bmatrix} + \begin{bmatrix} \sin(\hat{\theta}) & \cos(\hat{\theta}) \\ -\cos(\hat{\theta}) & \sin(\hat{\theta}) \end{bmatrix} \begin{bmatrix} \tilde{i}_d \\ \tilde{i}_q \end{bmatrix} \quad (5)$$

$$\begin{bmatrix} i_{\alpha-ref} \\ i_{\beta-ref} \end{bmatrix} = \begin{bmatrix} \sin(\hat{\theta}) & \cos(\hat{\theta}) \\ -\cos(\hat{\theta}) & \sin(\hat{\theta}) \end{bmatrix} \begin{bmatrix} \tilde{i}_d + i_{dc} \\ i_q \end{bmatrix} \quad (6)$$

The reference currents in the (abc) frame are given by:

$$\begin{bmatrix} i_{a-ref} \\ i_{b-ref} \\ i_{c-ref} \end{bmatrix} = \sqrt{\frac{2}{3}} \begin{bmatrix} 1 & 0 \\ -\frac{1}{2} & \frac{\sqrt{3}}{2} \\ \frac{1}{2} & -\frac{\sqrt{3}}{2} \end{bmatrix} \begin{bmatrix} i_{\alpha-ref} \\ i_{\beta-ref} \end{bmatrix} \quad (7)$$

The control strategy scheme based on synchronous reference frame theory is shown in Fig.1:

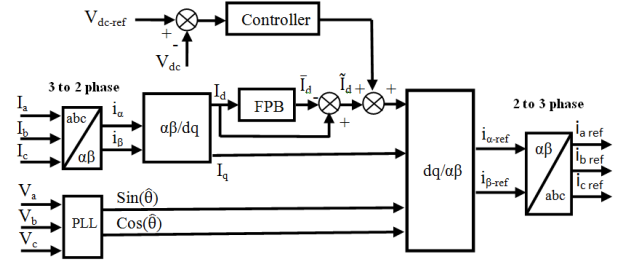

Fig.1. Synchronous reference frame theory

3. DC voltage control

When the SAPF is compensating the harmonic and reactive power components, the dc capacitor voltage V_{dc} varies. Hence V_{dc} is also sensed and regulated at a reference value in order to establish a self-sufficient energy at the dc bus.

The regulation loop consists of the comparison of the measured voltage with the reference voltage, admitting that the function of the system to be controlled is given by [12,17]:

$$G(s) = \frac{V_a^2}{(V_{dc-ref} \cdot C_{dc} \cdot s)} \quad (8)$$

The closed loop transfer function using a PI regulator is given by:

$$\frac{V_{dc}}{V_{dc-ref}} = \frac{(k_p + k_i/s) \cdot (V_a^2 / (V_{dc-ref} \cdot C_{dc} \cdot s))}{1 + (k_p + k_i/s) \cdot (V_a^2 / (V_{dc-ref} \cdot C_{dc} \cdot s))} \quad (9)$$

The development of this equation gives:

$$\frac{V_{dc}}{V_{dc-ref}} = \frac{\frac{k_p V_a^2}{V_{dc-ref} \cdot C_{dc}} \cdot s + \frac{K_i}{V_{dc-ref} \cdot C_{dc}}}{s^2 + \frac{k_p V_a^2}{V_{dc-ref} \cdot C_{dc}} \cdot s + \frac{K_i V_a^2}{V_{dc-ref} \cdot C_{dc}}} \quad (10)$$

A second order characteristic equation of the closed loop system is deduced:

$$s^2 + 2\xi\omega_n s + \omega_n^2 = 0 \quad (11)$$

Where:

$$\omega_n = \sqrt{\frac{K_i V_a^2}{V_{dc-ref} \cdot C_{dc}}}, \quad \xi = \frac{K_p V_a}{2\sqrt{K_i V_{dc-ref} \cdot C_{dc}}} \quad (12)$$

From (11) the proportional and integrator coefficient K_p , K_i of the controller can be deduced:

$$K_p = \frac{2 \cdot \xi \cdot K_i}{\omega_n}, \quad K_i = \frac{\omega_n^2 \cdot V_{dc-ref} \cdot C_{dc}}{V_a^2} \quad (13)$$

The expression of the current I_{cd} to compensate the inverter losses and maintain the constant dc-link voltage is given by:

$$I_{cd} = k_p \cdot \Delta V_{dc} + k_i \int \Delta V_{dc} \cdot dt \quad (14)$$

To obtain optimal dynamic performance for the system, the value of the damping ration ξ must be equal a 0.707.

4. Simulation and results

The simulink model of the proposed system is represented in fig.2. The hybrid active power filters are connected between the buses B1 and B2, through breaker. For analysis of the harmonics three cases were taken under consideration. Case 1 with the filters not connected to the lines, case 2 with the passive filters connected to the lines and the case 3 the HVDC rectifier with hybrid active filter connected to the lines.

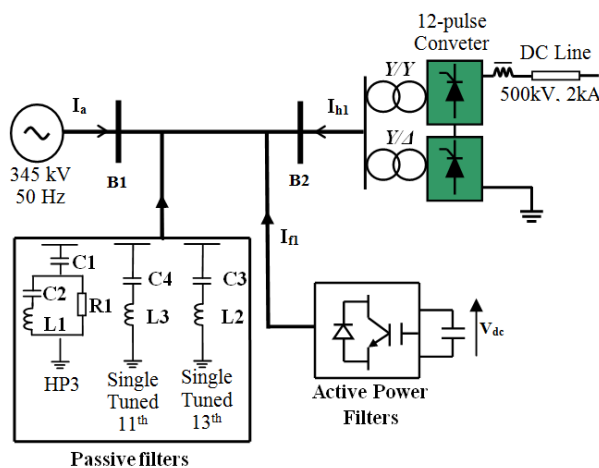

Fig.2. Simulink model of 12-pulse HVDC converter with hybrid filter connection.

The simulation model scheme has been built in MATLAB/SIMULINK, based on the following parameters : The voltage source 345 kV with fundamental frequency 50 Hz. U_c of 500 kV, I_c of 2 kA, and DC of 12 pulse HVDC rectifier. Two thyristor bridges of six pulses were used to build rectifier in series connection. Feeders consist of RLC elements, which are used to connect source to rectifier. The system is linked to converter using three-phase transformer (three winding). The load comprises of a resistive and inductive load connected to dc side. The value of inductance is 0.5H with 1200 MW load resistance.

In this paper, the two filter configurations that satisfy the specified performance are as follows:

A. Hybrid filters:

The simulation diagram in Fig.2 has shown the hybrid filter that consists of active filter and passive filters. The role of the active filter is to maintain and improve the performances of filtering in function the network and load evolution while, the passive filter deals with the compensation of good part of the harmonics. The aims of using three parts of harmonic filtering in hybrid filter are:

- Two single-tuned filters for 11th and 13th of 300Mvar,
- A conventional HP3 passive filter for the 3rd

harmonic of 150 Mvar,

- Shunt active filter for higher order harmonics (for example, 23rd to 49th) supplying 150 Mvar reactive power.

B. Passive filters

The simulation diagram with Passive Power Filter is shown in Fig.3. It consists of the source, non-linear load, and three phase harmonic filters.

Nonlinear elements such as power electronic converters generate harmonic currents or harmonic voltages, which are injected into power system. The resulting distorted currents flowing through the system impedance produce harmonic voltage distortion. Three-phase harmonic filters that shunt elements, are used in power systems for decreasing voltage distortion and for power factor correction. The filters reduce distortion by diverting harmonic currents in low impedance paths, and are designed in such way to be capacitive at fundamental frequency to produce reactive power required by converters and for power factor correction [19].The passive filter consists of four filters of harmonic:

- One C-type high-pass filters to the 3rd of 150 Mvar.
- Double tuned 11th/ 13th filters of 300Mvar.
- One high-pass filter tuned to the 24th of 150Mvar.
- One capacitor banks of 150 Mvar, modeled by a “Three-Phase Harmonic Filters “are used in HVDC line.

In order to achieve an acceptable distortion, several banks of filters of different types are usually connected in parallel. The combinations of different banks are derived from basic filters, such as Butterworth, Chebyshev and Cauerfilters [18]. The most commonly used filter types are [19]:

1. Band-pass filters, which are used to filter lowest order harmonics such as 5th, 7th, 11th, 13th etc. Band-pass filters can be tuned at a single frequency (single tuned filter), or at two frequencies (double-tuned filter).

2. High-pass filters, which are used to filter high-order harmonics and cover a wide range of frequencies. A special type of high-pass filter, the C-type high-pass filter, is used to provide reactive power and avoid parallel resonances. It also allows filtering low order harmonics (such as 3rd), while keeping zero losses at fundamental frequency.

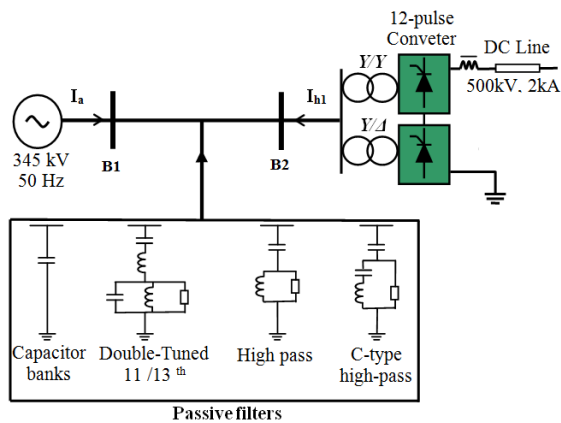

Fig.3. Simulink model of 12-pulse HVDC converter with passive filters connection.

Table 1
Simulation parameters

Line Voltage of the AC network	345 kV
Frequency	50 Hz
Transformer	Yg/Δ ,1200 MVA
DC Cables	$U_c = 500$ kV, $I_c = 2$ kA, $L = 0.5$ H
Active Filter	$V_{dc} = 10$ kV

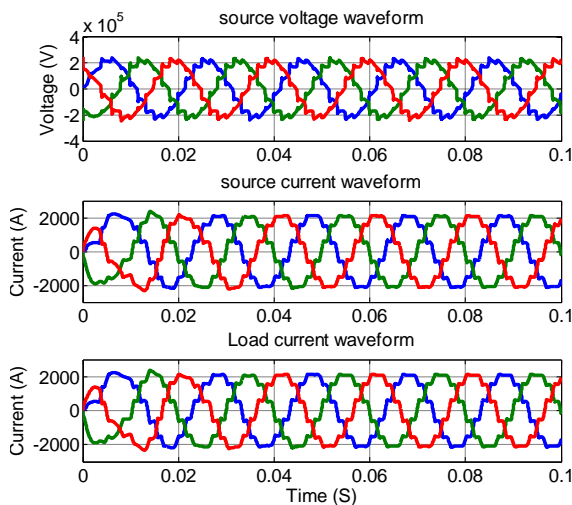

Fig.4. Voltages and currents in uncompensated HVDC system

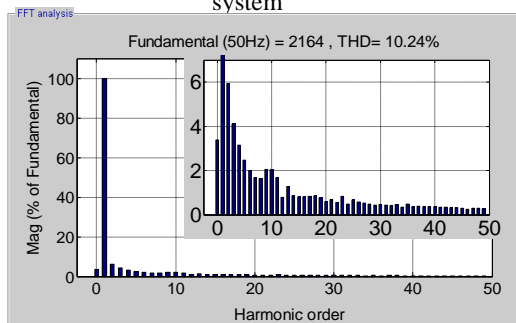

Fig. 5. Harmonics spectrum of source current without filter

The first case has been considered when circuit breaker is open, it can be seen that harmonics are present in voltages and currents in Fig. 4. We can observe, in the absence of the filters (hybrid or passive), three phase currents at the bus B1 and B2 are getting distorted due to the harmonics injected by the non-linear load.

Fig. 4 shows the waveform of supply currents before compensation. It consists of fundamental current as well as the harmonic current due to the non-linear load. The harmonics order spectrum of fig. 4 is shown in Fig. 5. It reveals the presence of the 11th, 13th and 23th, 25th and 35th, 37th,... etc. harmonics in the phase current. The current total harmonic distortion (THD) calculated for the 50 first harmonics before filtering is 10.24 % for case 1, without any filters.

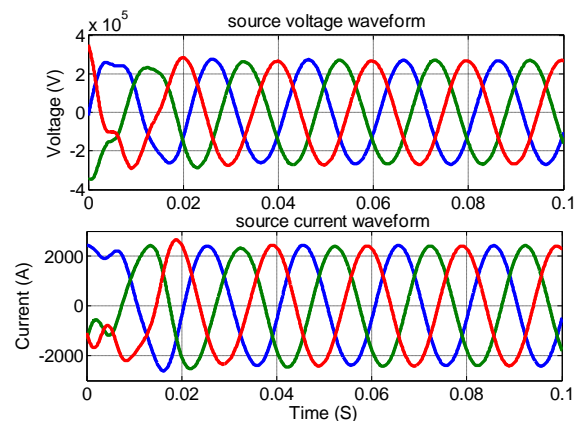

Fig.6. Voltages and currents in compensated HVDC system with Passive filters connection

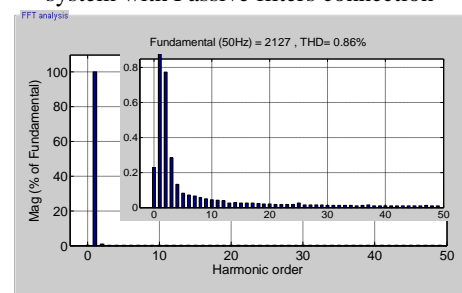

Fig.7. Harmonic spectrum of source current with passive filters connection

Next two cases have been considered when circuit breaker is closed and compensation is applied, it can be seen that in Fig. 6 and 8.

Fig.6 shows the waveforms of supply currents, with connected passive filters. It consists of fundamental current only. Use of the Passive Power Filter eliminates the harmonic current, which was present in the supply current in the earlier case. Fig. 7 shows the spectrum analysis of supply current after compensation. The Total Harmonic Distortion of the supply current is reduced from 10.24% to 0.86%.

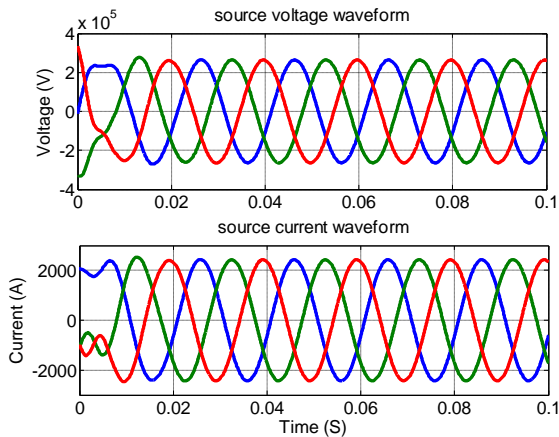

Fig.8. Voltage and Current in compensated HVDC system with Hybrid filter connection

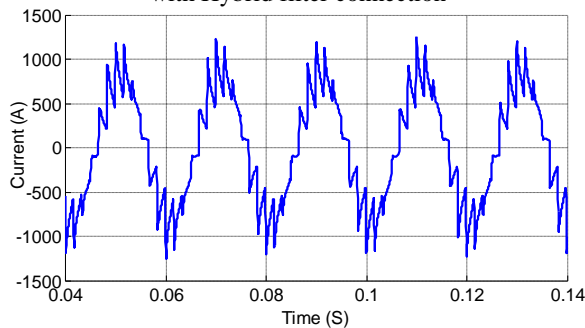

Fig.9. Active Filter injecting current i_{f1} (A)

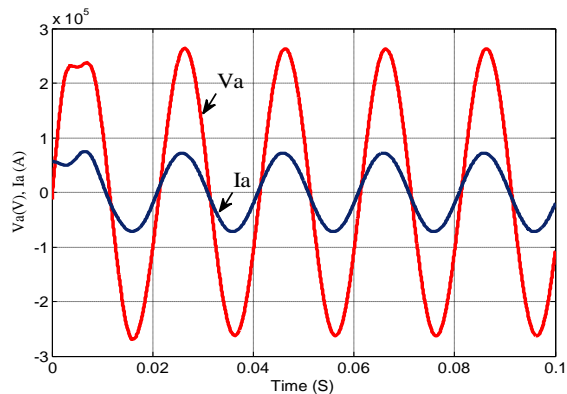

Fig.10. Power factor correction (V_a & $30 \cdot I_a$) with hybrid filter connection

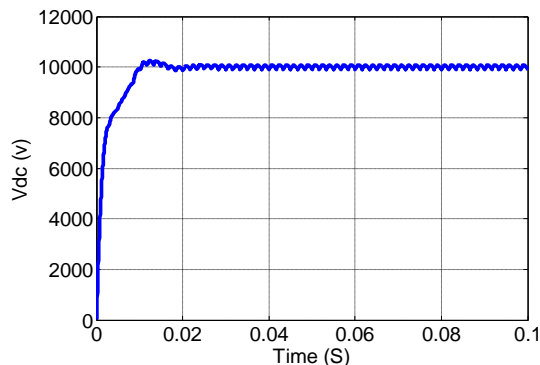

Fig.11. DC voltage regulation.

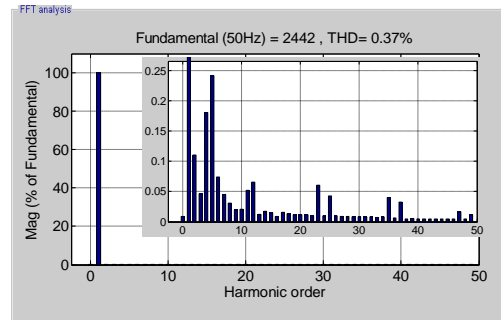

Fig.12. Harmonic spectrum of source current with hybrid filter connection

Fig.8 shows the waveforms of supply currents with connected hybrid filter. It consists only of fundamental current, of the waveform, which is more sinusoidal in comparison to other techniques. The intervention of the active filter is caused by injection of the polluting current as shown in Fig. 9, where the power factor of source current is set to unity, as shown in Fig. 10. Figure 11 shows the DC-link capacitor voltage.

Fig. 12 shows the Total Harmonic Distortion of the supply current THD, with considerable reduction level from 10.24 % for the case without any filters, to 0.37 % for the case with hybrid filter (less than 5% IEC norm). Using the hybrid filter Power Filter can eliminate the harmonic current presented in the supply current.

5. Conclusion

A filtering technique combining Passive power and Shunt Active Power Filter is proposed in this research. It can reduce effectively the harmonics of 12-pulse HVDC converter. The model was validated using MATLAB/ Simulink. The voltage and current waveforms were distorted because of the presence of harmonics. Proposed control strategy, in order to compensate harmonic currents is based on the synchronous reference frame theory.

The compensation principle applied to this system is quite different from conventional shunt passive and hybrid power filters. With the proposed control algorithm, the hybrid filter improves the harmonic compensation features of the passive filter and the power factor of the load.

The problem of distortion in 12-pulse HVDC converter is reduced to a great extent using Hybrid Power Filter. Overall, this compensation technique not only reduces the harmonics but also ensures the improvement of the system performance.

References

1. Zhang, Z., Xu, Z., Xue, Y., Tang, G.: *DC-Side Harmonic Currents Calculation and DC-Loop Resonance Analysis for an LCC-MMC Hybrid HVDC Transmission System*. In: IEEE Transactions on Power Delivery, 2014, Vol. 30, No. 2, p. 642-651.

2. Li, Y., Luo, L., Rehtanz, C., Yang, D., Rüberg, S., Liu, F.: *Harmonic Transfer Characteristics of a New HVDC System Based on an Inductive Filtering Method*. In: IEEE Transactions on Power Electronics, 2012, Vol. 27, No. 5, p. 2273- 2283.
3. Sanjib, K.N., Ridown, R.R., Siddikur, R.Md., *Investigation of THD on a 12-pulse HVDC transmission network and mitigation of harmonic currents using passive filters*. In: IEEE 2nd International Conference on Proceedings of International Conference on Electrical Information and Communication Technology. 10-12 Dec. 2015, p. 510-515.
4. Chebabhi, A., Fellah, M.K., Benkhoris, M.F.: *3D space vector modulation control of four-leg shunt active power filter using pq0 theory*. In: Rev. Roum. Sci. Techn. – Électrotechn. et Énerg., Vol.60, No.2, p. 185-194, Bucarest, 2015.
5. Anuradha, V., Anitha, S., Apoorva, D.C., Priyanka, N., Somashekar, B.: *Harmonic Analysis in HVDC System*. In: International Journal of Emerging Technology and Advanced Engineering, Vol. 4, No. 5, May 2014.
6. Kumar, P., Prakash, P.: *Harmonic Filter Design for HVDC Lines Using Matlab*. In: International Journal of Computational Engineering Research, Vol. 03, No.11, November 2013.
7. Jintakosonwit, P., Fujita, H., Akagi, H.: *Control and Performance of a Fully Digital Controlled Shunt Active Filter for Installation on a Power Distribution System*. In: IEEE Trans on Power Electronics, 2002, Vol. 17, No. 1, p. 132-140.
8. Lam, C.S., Cui, X.X., Choi, W.H., Wong, M.C., Han, Y.D.: *Minimum inverter capacity design for LC-hybrid active power filters in three-phase four-wire distribution systems*. In: IET Power Electronics, 2012, Vol. 5, No. 7, p. 956-968.
9. Nguyen, T.N., Luo, A., Shuai, Z., Chau, M.T., Li, M., Zhou, L.: *Generalised design method for improving control quality of hybrid active power filter with injection circuit*. In: IET Power Electronics, 2012, Vol. 5, No. 7, p. 1204 - 1215.
10. Li, Y., Liu, F., Saha, T.K., Krause, O., Cao, Y.: *Hybrid inductive and active filtering method for damping harmonic resonance in distribution network with non-linear loads* In: IET Power Electronics, 2015, Vol. 8, No. 9, p. 1616-1624.
11. Singh, B., Dube, S.K., Arya, S.R.: *An improved control algorithm of DSTATCOM for power quality improvement*. In: Electrical Power and Energy Systems 2015, No. 64, p.493–504.
12. Chebabhi, A., Fellah, M.K., Kessal, A., Benkhoris, M.F.: *Comparative Study of reference currents and DC bus voltage Control for Three Phase Four Wire Four Leg SAPF to Compensate Harmonics and Reactive Power with 3D SVM*. In: ISA Transactions 2015, No.57, p. 360-372.
13. Geddada, N., Mishra, M.K., Kumar, M.V.M.: *SRF based current controller using PI and HC regulators for DSTATCOM with SPWM switching*. In: Electrical Power and Energy Systems 2015, No. 67, p. 87-100.
14. Tedjini H., Meslem, Y., Rahli, M., Berbaoui, B., *Shunt Active Filter in Damping Harmonics Propagation*. In: Advances in Electrical and Computer Engineering, Vol. 10, No. 3, 2010, p. 108-113.
15. Islam, F.R., Pota, H.R., :*Virtual active filters for HVDC networks using V2G technology*. In: International Journal of Electrical Power & Energy Systems, January 2014, Vol. 54, , p. 399-407.
16. Joseph, T., Ugalde-Loo, C.E., Liang, J., Coventry, P.: *Active Filtering Based Current Injection Method for Multi Modal SSR Damping in an AC/DC system*. In: IEEE 17th European Conference on Power Electronics and Applications, At Geneva, Switzerland 8-10 Sept. 2015, p. 1-10.
17. Chennai, S.: *Fuzzy Logic Controller for Three-Level Shunt Active Filter to Mitigate Current Harmonics with Neutral Point Voltage Unbalances Control*. In: Journal of Electrical Engineering : Vol. 14 / 2014 - Edition : 1.
18. Singh, D.K., Godara, N., Jha, A.K.: *Enhancement of the power quality using active and passive filter*. In: International Journal of Advanced Technology in Engineering and Science, Vol. 03, No. 06, June 2015, p. 62-76.
19. Kumar, P., Prakash, P.: *Harmonic Filter Design for Hvd Lines Using Matlab*. In: International Journal of Computational Engineering Research, Vol. 03, No.11, November 2013, p. 12-19.