

Adaptive type-1 fuzzy control of a wind energy conversion system based on a double-fed induction machine

Abstract. In this paper, we will develop an adaptive control algorithm applied to the wind energy conversion system (WECS) based on a double-fed induction machine (DFIM) driven by a turbine with variable blade pitch, and controlled through the rotor variables by two bidirectional converters. The main function of these converters in the considered system is the connection of the wind generator to the power grid in two different ways: one on the grid side converter which will allow continuous bus control and improve the power factor on the grid side; the other, on the converter on the rotor side, which will allow the control and optimization of the energy flow generated by the stator during the periods of operation of this system. In the first part we presented the individual modeling of the wind turbine chain, then we presented and developed the controls necessary to control the active and reactive powers produced by this system in order to ensure optimum performance and production quality.

Streszczenie. W niniejszym artykule opracujemy algorytm sterowania adaptacyjnego zastosowany w systemie konwersji energii wiatru (SKEW) oparty na dwustronnie zasilanej maszynie indukcyjnej (DZMI) napędzanej turbiną o zmiennym skoku łopatek i sterowanej poprzez zmienne wirnika dwoma dwukierunkowymi konwerterami. Główną funkcją tych przekształtników w rozpatrywanym systemie jest podłączenie generatora wiatrowego do sieci elektroenergetycznej na dwa różne sposoby: jeden po stronie przekształtnika sieciowego, który umożliwi ciągłą kontrolę magistrali i poprawi współczynnik mocy po stronie sieci; drugi, na przekształtniku po stronie wirnika, co pozwoli na sterowanie i optymalizację przepływu energii generowanej przez stojan w okresach pracy tego układu. W pierwszej części przedstawiliśmy indywidualne modelowanie łańcucha turbiny wiatrowej, następnie przedstawiliśmy i opracowaliśmy sterowanie niezbędne do sterowania mocą czynną i bierną wytwarzaną przez ten system w celu zapewnienia optymalnej wydajności i jakości produkcji. (Adaptacyjne sterowanie rozmyte typu 1 systemem konwersji energii wiatrowej w oparciu o dwustronnie zasilaną maszynę indukcyjną)

Keywords: Adaptive control, Modelling, Type 1 Fuzzy logic control, wind energy conversion system.

Słowa kluczowe: Sterowanie adaptacyjne, modelowanie, sterowanie Fuzzy logic typu 1, system konwersji energii wiatrowej.

Introduction

The current global energy system is based on the massive use of fossil fuels which are not indefinitely sustainable given the limited reserves and the environmental damage which is becoming increasingly evident [1, 2]. It is for these reasons that we have been witnessing, for decades, a strong development of the energy sector oriented towards renewable energy sources such as solar and wind energy [3, 4, and 5].

Wind energy is a type of renewable energy whose primary source is directly drawn from the force of the wind [6, 7]. The most common way to exploit this form of energy is through the use of wind turbines based on several types of electrical machines. Thus, it should be noted that the energy yields and the maximum exploitation of this energy source is dependent on the type of machines as well as the associated controls [8, 9].

Today, most wind turbines are equipped with double-fed induction machines (DFIG). These types of machines offer several advantages over other types of machines also used in wind turbines, namely: operation over a wide range of wind speeds and extraction of the maximum possible power for each of its speeds. In this type of machine, the power converters and their control play a key role, particularly in the optimal transfer of power to the network and compliance with current energy quality standards [10, 11, and 12].

Research efforts in the field of automation have enabled the development of many advanced control technologies that have enabled the renewable energy sector in general and wind energy in particular to see its development and installation in a way surprising. However, this is still a very open area, and the search for solutions to the inherent problems of underlying source randomness and its impact on the network is still active [13, 14].

In this paper, two control techniques are developed to independently control the active and reactive power generated by the DFIG in a grid-coupled wind power generation system. These commands highlight the fact of acting on the rotor voltages in order to obtain the powers

generated at the terminals of the stator of the desired DFIG, namely: the active power which will be adjusted to that of reference generated by the turbine to ensure better efficiency of the wind system, and the reactive power which will be kept zero so as to keep a unity power factor on the stator side to ensure optimum production quality. Starting from there, we propose: I: type 1 fuzzy logic control based on type 1 fuzzy regulators, this method ensures decoupling and robustness in closed loop at all times; II: type 1 adaptive fuzzy logic control based on adapting controllers to solve parametric variation problems.

The following of this paper is organized as follows: The next section will be presented the mathematical model of each part of the variable speed wind power conversion chain. In section 2, control by type 1 fuzzy logic to control the two power outputs. In section 3, we will develop another adaptive type 1 fuzzy logic control to improve the control. In section 4 will be devoted to the qualitative and robustness comparative study between the two developed commands in order to highlight the effectiveness and robustness of each of them. Finally, the work will be closed with a conclusion

Modeling of the different system parts

To simulate the behavior of this system under different stresses and thus to understand the mechanisms that govern its operation, requiring the individual modeling of our system, namely:

- The double-fed induction machine which is chosen as the generator in our wind system;
- The machine side converter that will permit the application of controls intended to control the energy flow generated;
- Grid side converter (two-level rectifier) which appears to be an effective solution for mains-side power factor improvement and continuous bus tuning;
- The wind turbine and its control to maximize and limit the power sensor during low and high wind speeds.

DFIG Model

The double-fed induction machine is a highly complex non-linear system, to command this machine in the different regimes of functioning, requires a more accurate mathematical modeling to represent its conduct in a satisfactory and real [15, 16].

$$(1) \quad \begin{cases} V_{sd} = R_s I_{sd} + \frac{d\varphi_{sd}}{dt} - w_s \varphi_{sq} \\ V_{sq} = R_s I_{sq} + \frac{d\varphi_{sq}}{dt} + w_s \varphi_{sd} \\ V_{rd} = R_r I_{rd} + \frac{d\varphi_{rd}}{dt} - w_r \varphi_{rq} \\ V_{rq} = R_r I_{rq} + \frac{d\varphi_{rq}}{dt} + w_r \varphi_{rd} \end{cases}$$

Stator side converter Model

DFIG-based variable speed wind power conversion systems require the use of a static converter (two-level inverter) that powers the machine rotor. The major goals of this inverter are: to ripple the DC bus voltage to supply it to the rotor winding and to enable the implementation of commands to control the powers produced by the stator of this machine and to inject them to the grid [17].

$$(2) \quad \begin{bmatrix} V_A \\ V_B \\ V_C \end{bmatrix} = \frac{E}{6} \cdot \begin{bmatrix} 2 & -1 & -1 \\ -1 & 2 & -1 \\ -1 & -1 & 2 \end{bmatrix} \begin{bmatrix} S_1 \\ S_2 \\ S_3 \end{bmatrix}$$

Grid side converter Model

The grid side converter (rectifier) has the same concept as the machine side converter (inverter) previously established. The advantage of the grid side converter, in addition to the power bidirectionality, allows the control of the active power by keeping the DC bus voltage constant, and set the reference reactive power to a null value in order not to alter the quality of the grid (unitary grid power factor) [17, 18].

$$(3) \quad \frac{d}{dt} \begin{bmatrix} i_1 \\ i_2 \\ i_3 \end{bmatrix} = \begin{bmatrix} -\frac{R}{L} & 0 & 0 \\ 0 & -\frac{R}{L} & 0 \\ 0 & 0 & -\frac{R}{L} \end{bmatrix} \begin{bmatrix} i_1 \\ i_2 \\ i_3 \end{bmatrix} + \frac{1}{L} \begin{bmatrix} V_1 - V_{an} \\ V_2 - V_{bn} \\ V_3 - V_{cn} \end{bmatrix}$$

$$(4) \quad \begin{bmatrix} V_A \\ V_B \\ V_C \end{bmatrix} = \frac{U_c}{3} \cdot \begin{bmatrix} 2 & -1 & -1 \\ -1 & 2 & -1 \\ -1 & -1 & 2 \end{bmatrix} \begin{bmatrix} S_1 \\ S_2 \\ S_3 \end{bmatrix}$$

$$(5) \quad \frac{U_c}{i_s} = \frac{R_{Ch}}{1 + R_{Ch} \cdot C \cdot p}$$

Grid-side converter control can take the form of cascade control. Two internal loops regulate the phase currents. An outer loop regulates the capacitive voltage.

$$(6) \quad \begin{cases} V_{pd} = V_d - R i_d - L \frac{di_d}{dt} + L \omega i_q \\ V_{pq} = V_q - R i_q - L \frac{di_q}{dt} - L \omega i_d \end{cases}$$

$$(7) \quad \begin{cases} P = \frac{3}{2} \cdot [V_d I_d + V_q I_q] \\ Q = \frac{3}{2} \cdot [V_q I_d - V_d I_q] \end{cases}$$

$$(8) \quad P_{ref} = U_{cmes} I_{red_ref} \quad \text{and} \quad (9) \quad Q_{ref} = 0$$

Modelling and control of the Turbine

All variable speed wind energy conversion systems are driven by a turbine with variable blade pitch to control the capture of energy from the wind during its low and high speeds, for its different wind speeds, one needs a precise and demanding modeling, and adequate control techniques to control this system [19, 20].

➤ Turbine Model

The turbine is composed of three identical blades of length R_T attached to a drive shaft connected to a speed multiplier having a transformation ratio G [19, 20].

$$(10) \quad C_T = \frac{1}{2} \cdot \frac{\rho \cdot \pi \cdot R_T^3 \cdot V^2}{\lambda} \cdot C_p(\lambda, \beta)$$

$$(11) \quad \lambda = \frac{\Omega_T \cdot R_T}{V}$$

$$(12) \quad C_p(\lambda, \beta) = (0,5 - 0,0167 \cdot (\beta - 2)) \cdot \sin \left[\frac{\pi \cdot (\lambda + 0,1)}{18,5 - 0,3 \cdot (\beta - 2)} \right] - 0,00184 \cdot (\lambda - 3) \cdot (\beta - 2)$$

$$(13) \quad G = \frac{C_T}{C_{Mec}} \quad \text{and} \quad (14) \quad G = \frac{\Omega_g}{\Omega_T}$$

$$(15) \quad C_{Mec} - C_g = J \cdot \frac{d\Omega_g}{dt} + f \cdot \Omega_g$$

➤ Turbine control

Two control techniques will be applied:

- One to maximize the power captured when the wind speed is lower than that necessary to reach the nominal power of the turbine "MPPT control" [20, 21].

The purpose of the control is to maximize the energy captured from the wind to extract the maximum power. For this, the two variables: pitch angle β and the specific speed λ must be maintained at their optimal values β_{opt} and λ_{opt} in order to ensure a maximum power coefficient C_{pmax} . The technique used in this case is called the MPPT (Maximum Power Point Tracking) technique [19, 20].

$$(16) \quad V = \frac{\Omega_T \cdot R_T}{\lambda_{opt}} \quad \text{and} \quad (17) \quad C_{Topt} = \frac{1}{2} \cdot \rho \cdot \pi \cdot R_T^3 \cdot V^2 \cdot \frac{C_p(\lambda_{opt})}{\lambda_{opt}}$$

Substituting the wind speed into the equation (17), the optimum torque becomes:

$$(18) \quad C_{Topt} = \frac{1}{2} \cdot \rho \cdot \pi \cdot R_T^5 \cdot \frac{C_p(\lambda_{opt})}{\lambda_{opt}^3} \cdot \Omega_T^2$$

It can be seen that the optimal aerodynamic torque is proportional to the square of the rotor speed:

$$(19) \quad C_{Topt} = k_{opt} \cdot \Omega_T^2 \quad \text{Such as} \quad (20) \quad k_{opt} = \frac{1}{2} \cdot \rho \cdot \pi \cdot R_T^5 \cdot \frac{C_p(\lambda_{opt})}{\lambda_{opt}^3}$$

In steady state, the mechanical equation is written in the form:

$$(21) \quad \frac{C_T}{G} - C_g - f \cdot \Omega_g = 0$$

By replacing (19) in equation (21), the mechanical equation becomes:

$$(22) \quad \frac{k_{opt}}{G} \cdot \Omega_r^2 - f \cdot \Omega_g - C_g = 0 \quad \text{with} \quad (23) \quad \Omega_g = G \cdot \Omega_r$$

If the electromagnetic torque C_g is controlled so as to follow the optimum torque, the wind turbine remains around its optimum efficiency curve; the torque becomes an optimum torque C_{gopt} .

$$(24) \quad C_{gopt} = \frac{k_{opt}}{G^3} \cdot \Omega_g^2 - f \cdot \Omega_g$$

- The other to limit the power produced to a value equal to the nominal power at high wind speeds "Pitch control". The purpose of controlling the blade orientation system is to limit and maintain the mechanical power produced by the turbine at its machine nominal value in order to preserve all the elements of the wind power chain around this power. An action on the pitch angle of the blades makes it possible to reduce the power coefficient and thus limit the converted power [21].

Active and reactive powers control

Currently, a major area of research is oriented towards control techniques for WECS based on artificial intelligence (fuzzy logic, neural network, genetic algorithm, etc.) [22].

Type 1 Fuzzy logic control

The principle of fuzzy logic control comes close to the human approach because the variables processed are not logical variables but linguistic variables, close to the human language. Moreover, these linguistic variables are processed with the help of rules which refer to a certain knowledge of the system behavior [23, 24, and 25].

We will apply this nonlinear control to continuously and independently control the active and reactive powers generated by our wind energy conversion system.

Applied command structure

Most fuzzy regulators for simple monovariable systems consist of the inputs of the fuzzy controller which are usually the error (the difference between the setpoint and the process output) and its variation (translation of the system dynamics). The majority of the developed controllers uses the very simple scheme proposed by Mamdani, as shown in the next figure:

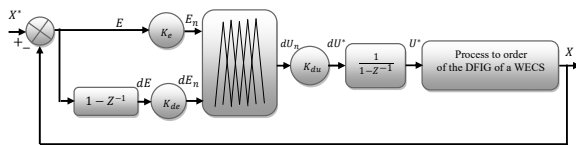

Fig.1. Basic structure of a type 1 fuzzy controller

According to the diagram above, the type 1 fuzzy regulator is essentially composed of:

- A block for calculating the change in error over time
- The scaling factors (K_e , K_{de} , et K_{du}) which are normalization and denormalization gains. The adequate selection of the latter ensures stability and targeted dynamic and static performance improvements of the system to be tuned; in addition, the input gains (K_e , K_{de}) minimize the physical input magnitudes in a range of variation called the universe of discourse.
- A fuzzification block of the error and its change. For the choice of the shape of the membership forms, we have chosen the triangular and trapezoidal forms.

- A defuzzification block for the variation of the control. The outputs of the inference system that are fuzzy values must be converted back to real output values so that the system can use them.

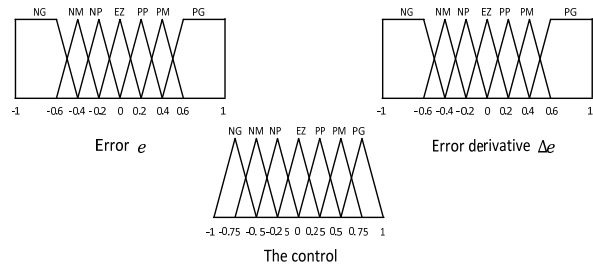

Fig.2. The membership functions used.

- The inference rules used to determine the output variable for adjusting the currents grouped in the table below. The inference method used is Mamdani's "min-max" method.

Table 1. Table of decision rules for the type 1 fuzzy controller

Control	Error						
	NB	NM	NS	Z	PS	PM	PB
Derived from error	NB	NB	NB	NB	NB	Z	Z
	NM	NB	NB	NM	NM	Z	Z
	NS	NB	NB	NS	NS	PS	PS
	Z	NB	NM	NS	Z	PS	PM
	PS	NM	NS	NS	PS	PS	PB
	PM	Z	Z	Z	PM	PM	PB
	PB	Z	Z	Z	PB	PB	PB

The block diagram of type 1 fuzzy logic control applied to a DFIG in a WECS is represented as follows:

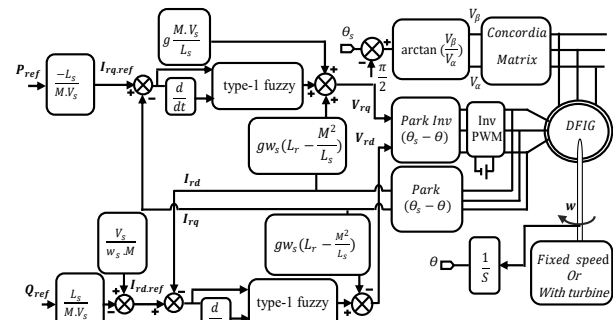

Fig.3. Block diagram of the type 1 fuzzy logic control structure

Numerical simulation results of the system for a fixed speed

The figures below show the performance of type 1 fuzzy logic control of the stator active and reactive powers applied to the DFIG. This test is carried out under the following conditions:

Machine connected to the grid and driven by a fixed speed of 1440 rpm with a negative rung for the active power (-1500w) between times $t = 1.5$ s and $t = 2.5$ s and a positive rung between times $t = 3.5$ s and $t = 4.5$ s (+ 1500w).

Always the machine connected to the grid and driven by a fixed speed of 1440 rpm with a positive rung for the reactive power (+1000 w) between times $t = 1.5$ s and $t = 2.5$ s and a negative rung between the times $t = 3.5$ s and $t = 4.5$ s (-1000w).

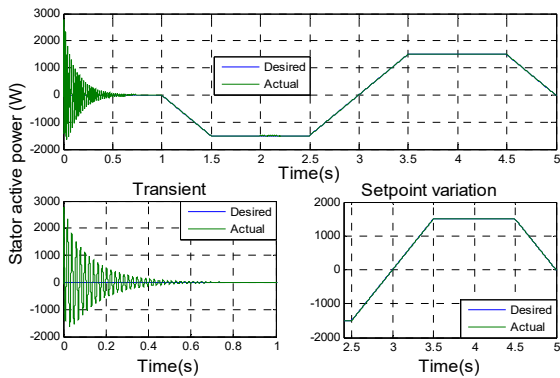

Fig.4. Stator active power

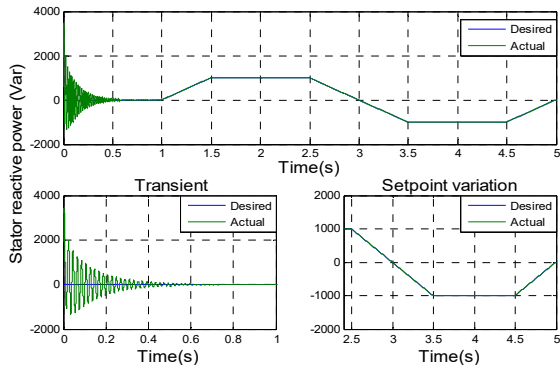

Fig.5. Stator reactive power

➤ **Interpretation of Results**

From the curves of the above figure, which represent the simulation results, it is clear that the fuzzy control technique type 1 allows a complete decoupling between the two components of the active and reactive stator power. The results from the simulation, clearly show that the use of this control manages to maintain the active and reactive power at their desired values with a fast response for the transient regime and for the setpoint change with a maximum minimization of error between the setpoint values and the measured one (almost zero).

Adaptive type-1 fuzzy logic control

The type 1 fuzzy controller could control any nonlinear system, but obtaining the right results was not always obvious because of the variation of the parameters of these systems. To solve this problem, the adaptive control has been integrated into the type 1 fuzzy controller to build a fuzzy adaptive controller for automatic adjustment, when the parameters of the process to be controlled are either unknown or time-varying [26, 27].

In this part we will try to apply the type-1 adaptive fuzzy control to adjust the active and reactive powers generated by our wind energy conversion system.

➤ **Applied command structure**

Nowadays, there are a number of studies on adaptive type-1 fuzzy control. However, these are restrictive studies due to the lack of appropriate tools. A fuzzy controller is said to be adaptive if one or more of its parameters that can be adjusted (gains, membership functions, rules) change during operation. So an adaptive fuzzy controller is a controller whose parameters change over time [26, 27].

In the following, we will present an adaptive type-1 fuzzy control technique; our goal here is to adapt only the output control gain in real time by a gain adjustment mechanism in order to obtain better control performance of our system in the case of parametric variation.

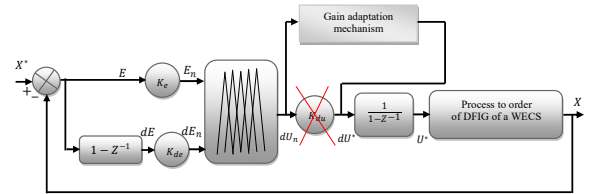

Fig.6. Basic structure of an adaptive type 1 fuzzy controller

- The adjustment mechanism is a type-1 fuzzy regulator, the membership functions for the error, and the control are represented as follows:

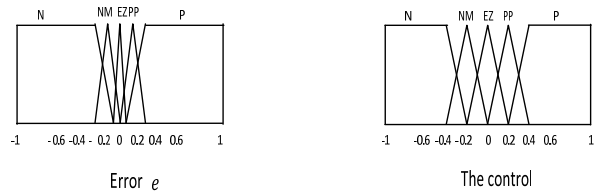

Fig.7. The membership functions used.

- the adjustment mechanism rules table is represented as follows:

Table 2. Table of decision rules of the gain adaptation mechanism for adaptive type-1 fuzzy control

Input	NB	NM	NS	Z	PS	PM	PB
Output	PB	PM	PS	Z	NS	NM	NB

The block diagram of the adaptive type1 fuzzy logic control applied to a DFIG in a WECS is represented as follows:

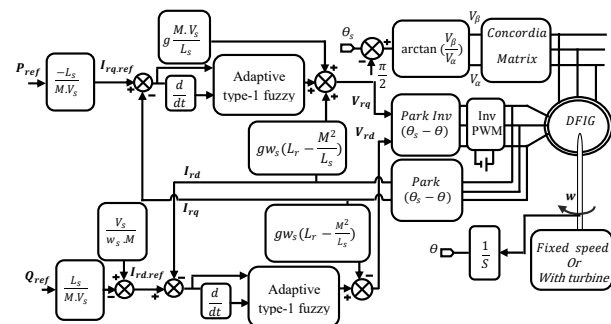

Fig.8. Block diagram of the Adaptive type 1 fuzzy logic control

➤ **Numerical simulation results of the system for a fixed speed**

To properly judge the type-1 adaptive fuzzy control, we have presented the same simulation tests carried out previously for the type-1 fuzzy control.

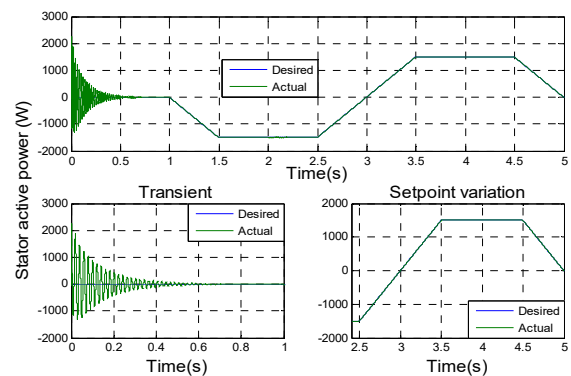

Fig.9. Stator active power

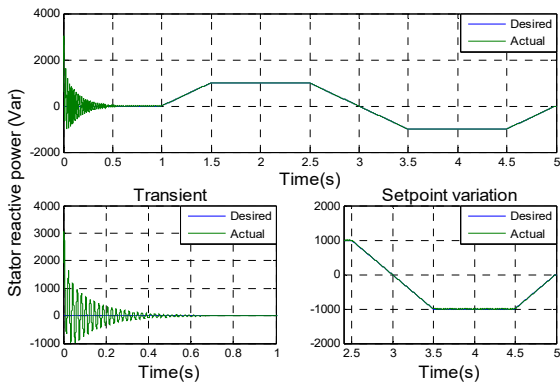

Fig.10. Stator reactive power

➤ **Interpretation of Results**

From the simulation results, it is clear that the new control presents positive performances compared to the previous control (type-1 fuzzy logic control), namely: a faster response time for the transient regime and for the setpoint change time, and an expected convergence of the errors to zero between the setpoint and the actual measured values.

➤ **Numerical simulation results of the system for a variable speed (with turbine)**

In the most practical case, the machine is directly coupled to the grid by the stator and driven by the rotor quantities through two bidirectional PWM converters, and driven by a turbine with variable blade pitch. The stator active power setpoint is determined from the mechanical power of the turbine, while the stator reactive power is kept zero to keep the unity power factor on the stator side of the DFIG. The time during which the measurements were made is 50s. The disturbances induced by the inverter do not make it possible to distinguish the difference between the two commands developed in the two transient and permanent regimes, the simulation results for the two commands are presented as follows:

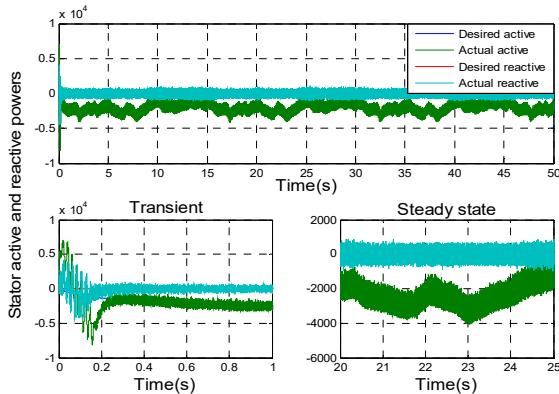

Fig.11. Active and reactive power generated by WECS for two controls type-1 fuzzy logic and adaptive type-1 fuzzy logic.

➤ **Interpretation of Results**

It can be seen that the stator active and reactive power curves generated by the machine for the two commands developed follow the reference curves with a lower response time in the transient state, a minimum overshoot of the power curves and fewer oscillations. active and reactive power values that quickly return to their reference speeds.

Parametric variation test

To review the two control techniques implemented and summarized on the wind power system considered in this

paper, we will present a parametric variation test that we have performed consists in varying the parameters of the machine used, because, in reality, they are subject to variations caused by various physical phenomena such as (saturation of inductances, heating of resistors, etc.). This test is called: robustness test.

In this test, the following parameters were varied:

Resistances R_s and R_r multiplied by 2.

Inductances L_s , L_r and M_{sr} , divided by 2.

The variation of the parameters will be applied between the times $t=2s$

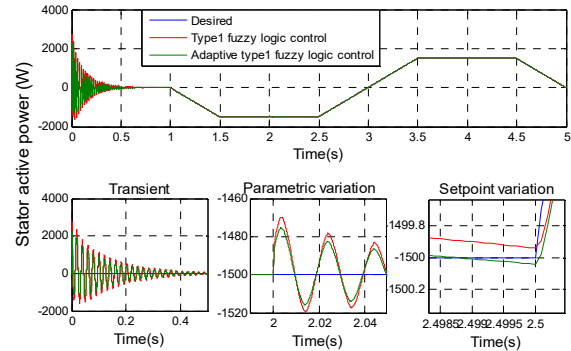

Fig.12. Stator active power

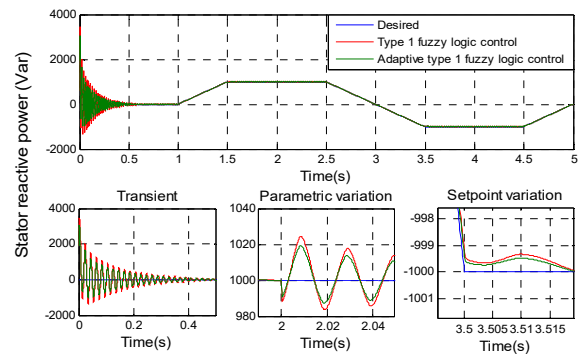

Fig.13. Stator reactive power

Interpretation of Results

In this experiment, we have visualized the shape of the active and reactive powers for a simulation time $T_s=5$. The two proposed controls present a strong robustness and ensure good performances either in the internal variation point (parametric variations), or for the external variation (setpoint variations); however, the adaptive fuzzy control type-1 presents itself as the best control having less wavy power shapes in comparison with the fuzzy control type-1 in the two variation points and for the transient regime.

Conclusion

The goal of this modest research work is to study, model and control a variable speed WECS. For this, a modeling of the various constituents of this system has been conducted. These patterns were used to elaborate two control techniques to ensure accurate and permanent control of the stator power produced while guaranteeing a stability and speed of tracking with almost zero static error. This resulted in a high performance of our system and excellent production quality..

This work was supported by university-Training Research Projects (PRFU) faculty of Technology and LGE Research Laboratory University of M'sila under the project number: A01L07UN280120220006

Authors

PhD student Labib bensaadia He received the M.Sc. degrees in Electrical Engineering from M'Hamed BOUGARA University of Boumerdès, Algeria, in 2012. His current area of research includes control of DFIM their use in producing wind energy. Email: labib.bensaadia@univ-msila.dz

Dr.Riyadh Rouabhi works in the Department of Electrical Engineering at M'sila University. His current research area includes the control of induction machines and RE. Email: riyadh.rouabhi@univ-msila.dz

Pr. Djaleddine Khodja works in the Department of Electrical Engineering at M'sila University. Email: djaleddine.khodja@univ-msila.dz

Dr. Abdelghafour HERIZI works in the Department of Electrical Engineering at M'sila University. His current research area includes the control of induction machines and RE. Email: abdelghafour.herizi@univ-msila.dz

REFERENCES

- [1] Rezaei MM., A nonlinear maximum power point tracking technique for DFIG-based wind energy conversion systems, *Engi Science and Techn, Inter Jou.*,21(2018),901-908
- [2] Darvish Falehi A., Rafiee M., Maximum efficiency of wind energy using novel Dynamic Voltage Restorer for DFIG based Wind Turbine, *Energy Rep.*,4(2018),308-322
- [3] Mekki M., Allaoui T., Belabbas B., Denai M., Decoupling Vector Control and Optimisation of PMSG-Based Wind Energy System Using Adaptive Type-1 and Type-2 Fuzzy Logic Control, *Przegląd Elektrotechniczny, ISSN 0033-2097 96 (2020), nr 8, 123-128*
- [4] Dahbi A., Nait-Said MS., Nait-Said N., A novel combined MPPT-pitch angle control for wide range variable speed wind turbine based on neural network, *inter jour hydro ener* , 41 (2016), n 22, 9427-9442
- [5] Ebin Cherian Mathew., Anandarup Das., Integration of renewable energy sources with MVDC network, *IEEE International Conference on Power Electronics, Drives and Energy Systems (PEDES) 2020 IEEE*
- [6] Kenan Dösoglu M., Aysen Basa Arsoy., Transient modeling and analysis of a DFIG based wind farm with supercapacitor energy storage, *Int J Electr Power Ener Syst.*,78(2016),414-441
- [7] Gajewski P., Improved control strategy of wind energy conversion system with PMSG during low voltage sags, *Przegląd Elektrotechniczny, ISSN 0033-2097 96 (2020), nr 4,123-128*
- [8] Nektarios E Karakasis., Christos A. Mademlis., High efficiency control strategy in a wind energy conversion system with doubly fed induction generator, *Renewable Energy.*,125(2018),974-984
- [9] Saihi L., Bakou Y., Ferroudji F., Berbaoui B., MPPTF & Pitch Fuzzy Controller of a Wind Turbine System Using DFIG, *2019 1st International Conference on Sustainable Renewable Energy Systems and Applications (ICSRESA) 2019 Algeria*
- [10] Andreas Giannakis., Athanasios Karlis., Yannis L. Karnavas., A combined control strategy of a DFIG based on a sensorless power control through modified phase-locked loop and fuzzy logic controllers, *Renewable Energy.*,121(2018),489-501
- [11] Prosenjit Mondal., Praveen Tripathy., Ujjwal K. Saha., Second Order Sliding Mode Observer Design for the Speed Estimation of DFIG, *IEEE International Conference on Power Electronics, Drives and Energy Systems (PEDES) 2020 IEEE*
- [12] Farshadnia M., V T., Current-based direct power control of a DFIG under unbalanced grid voltage, *Int J Electr Power Ener Syst.*,62(2014),571-582
- [13] Ayirir W., Ourahou M., El Hassouni B., Haddi A., Direct torque control improvement of a variable speed DFIG based on a fuzzy inference system, *Mathematics and Computers in Simulation.*,167(2020),308-324
- [14] Abdullah Asuhaimi B. Mohd Zin., Mahmoud Pesaran H.A., Azhar B. Khairuddin., An overview on doubly fed induction generators' controls and contributions to wind based electricity generation, *Renewable and Sustainable Energy Reviews.*,27(2013),692-708
- [15] Amrane F., Chaiba A., Francois B., Suitable Power Control based on Type-2 Fuzzy Logic for Wind-Turbine DFIG Under Hypo-Synchronous Mode Fed by Multi-Level Converter, *The 5th International Conference on Electrical Engineering-Boumerdes, Algeria. (ICEE-B) 2017 IEEE*
- [16] Vall Hemeyine A., Abbou A., Bakouri B., Labbadi M., Power Control for Wind Turbine Driving a Doubly Fed Induction Generator using Type-2 Fuzzy Logic Controller, *2019 IEEE*
- [17] Rouabhi R., Abdessemed R., Chouder A., Djerioui A., R., Power Quality Enhancement of Grid Connected Doubly-Fed Induction Generator Using Sliding Mode Control, *International Review of Electrical Engineering.*,10(2010), nr 2,266-276
- [18] Kara R., Tlemcani A., Hassaoui N., Interval type-2 fuzzy logic controller based DPC-SVM algorithm for PWM rectifier, *Przegląd Elektrotechniczny, ISSN 0033-2097 97 (2021), nr 7, 80-84*
- [19] FENG Hao., PAN Lei., PENG Xiu-fang., Zhang Tian-wei., Coordinated Control Strategy of MPPT and Pitch angle of Wind Turbine Generator Based on Neural Network, *2019 IEEE, 99-104*
- [20] Afdhal A., Dhaoui M., Sbita L., Pitch Angle control of the variable speed wind turbine, *The 17th international conference on Sciences and Techniques of Automatic control & computer engineering - STA'2016, Sousse, Tunisia 2016 IEEE, 582-587*
- [21] Kang Qi., Research on Variable Pitch Wind Turbine Control System, *2014 IEEE*
- [22] Rouabhi R., Control of the powers generated by a variable-speed wind system based on a DFIG, *PhD thesis, batna university 2, (2016)*
- [23] Herizi J., Rouabhi R., Zemmit A., Comparative study of the performance of a sliding, sliding-fuzzy type 1 and a sliding-fuzzy type 2 control of a permanent magnet synchronous machine, *Przegląd Elektrotechniczny, ISSN 0033-2097 98 (2022), nr 11, 21-29*
- [24] Fahrizal Auliansyah., Sutodjo., Ony Asrarul Qudsi., Indra Ferdiansyah., Controlling Speed Of Brushless DC Motor By Using Fuzzy Logic Controller, *International Sem in ar on Application for Technology of Information and Communication (iSem antic) 2020 IEEE, 298-304*
- [25] Khelifa S., Semmah A., Power quality enhancement in wind turbine based DFIG using fuzzy control and neural-RIP for harmonic mitigation, *Przegląd Elektrotechniczny, ISSN 0033-2097 98 (2022), nr 5, 140-147*
- [26] Yongqing Fan., STongtong Kang., Type-2 Fuzzy Adaptive Control For Uncertain Robot Manipulator System With Time-Varying Output Constraints, *2020 IEEE, 2430-2435*
- [27] Ayad Al-Mahturi., Fendy Santoso., An Intelligent Control of an Inverted Pendulum Based on an Adaptive Interval Type-2 Fuzzy Inference System, *2019 IEEE*